

Modello a pavimento
Floored model
Modèle au sol
Überflur-Modell

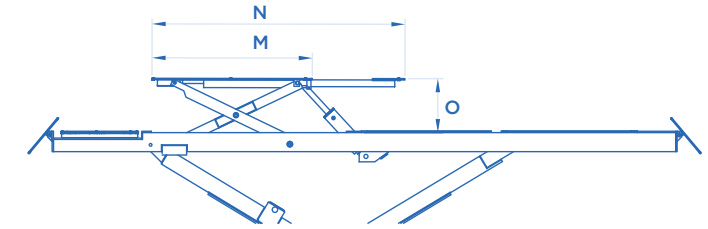

ART.	LIFT TABLE	M mm	N mm	O mm
825 • 825/I	3000 Kg	1420	1870	400
805 • 815	4000 Kg	1465	2000	400

Modello a scomparsa
Disappearing model
Modèle encastrable
Unterflur-Modell

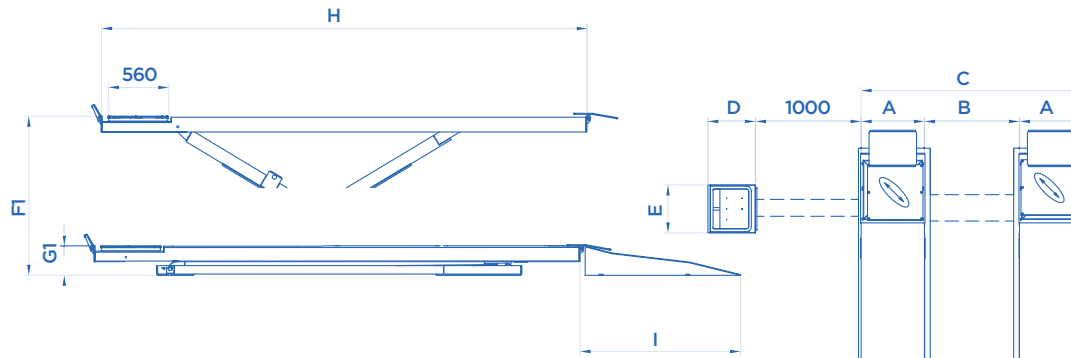
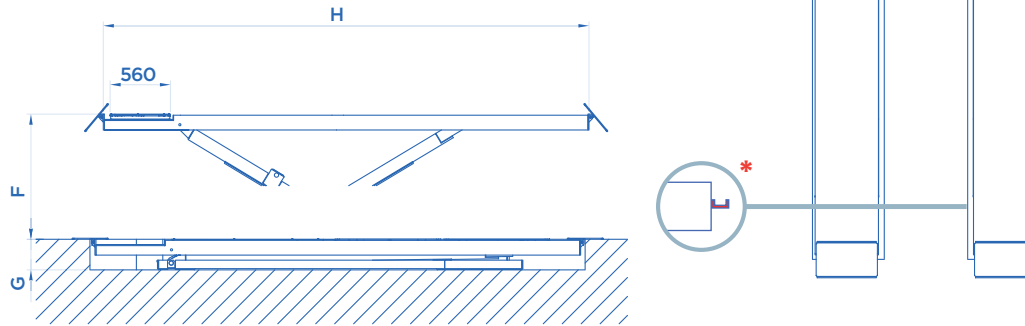

ART.	LIFT TABLE	Motor	Three-phase motor Moteur triphasé Netzspannung	A mm	B mm	C mm	D mm	E mm	F mm	F1 mm	G mm	G1 mm	H mm	I mm	KG
840 840/I	3500 Kg	4 kW	400V • 50HZ	650 650	900 900	2200 2200	460 460	450 450	1800	1880	290	280	5100 5100	1500	1900 1750
825 825+853/A 825/I 825/I+853/A 826 826+853/A 826/I 826/I+853/A	4000 Kg	3,3 kW	400V • 50HZ	600 600 600 600 600 600 600 600	900 900 900 900 900 900 900 900	2100 2100 2100 2100 2100 2100 2100 2100	460 460 460 460 460 460 460 460	450 450 450 450 450 450 450 450	1800 1800 1800 1800 1800 1800 1800 1800	1880 1880 1880 1880 1880 1880 1880 1880	290 290 290 290 290 290 290 290	280 280 280 280 280 280 280 280	4600 4600 4600 4600 4600 4600 4600 4600	1500 1500 1500 1500 1500 1500 1500 1500	2490 2540 2200 2250 2100 2150 1850 1900
805 805+853/B 815 815+853/B 805/A 805/A+853/B 815/A 815/A+853/B	5000 Kg	4 kW	400V • 50HZ	650 650 650 650 650 650 650 650	900 900 900 900 900 900 900 900	2200 2200 2200 2200 2200 2200 2200 2200	500 500 500 500 500 500 500 500	550 550 550 550 550 550 550 550	1800 1800 1800 1800 1800 1800 1800 1800	1880 1880 1880 1880 1880 1880 1880 1880	290 290 290 290 290 290 290 290	280 280 280 280 280 280 280 280	4900 4900 4900 4900 4900 4900 4900 4900	1700 1850 1850 1700 1850 1850 1700 1850	3040 3110 2750 2820 2480 2550 2230 2300